

Wisconsin State
Council

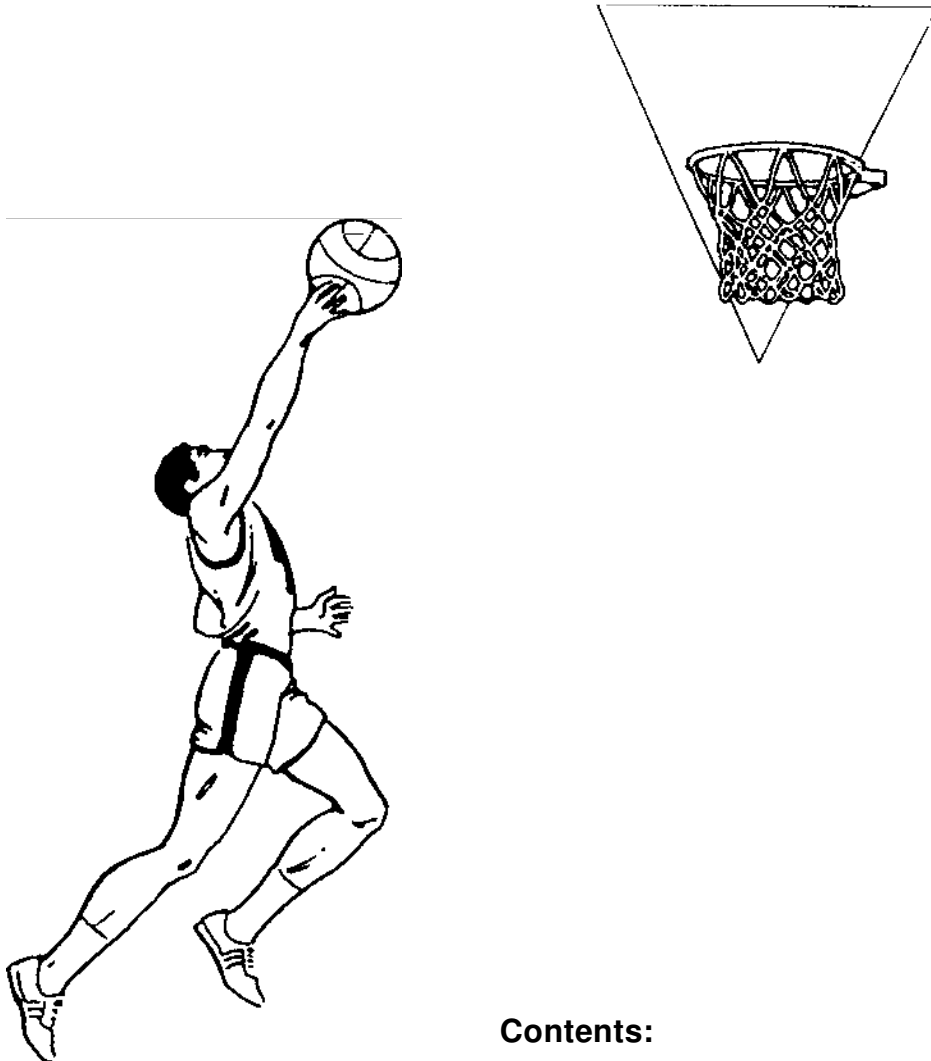

Knights of
Columbus

FREE THROW CHAMPIONSHIP



Contents:

**Rules a Regulations
Sample Invitation Letter
Winner & Contest Report
Ball Specifications and Diagram**

RULES AND REGULATIONS

IMPORTANT FIRST:

You must order (early) from Supreme's Service Department, your Free-Throw Data Package. The Councils will receive posters, certificates, and forms. The District Deputies will receive data going to the Councils plus their District Awards. All Councils and District Deputies must request data from:

Knights of Columbus Supreme Service Department
One Columbus Plaza
New Haven, CT 06507

The Knights of Columbus Basketball Free Throw Championship is open to all boys and girls ages 10 to 14 inclusive. Age eligibility is to be determined by the age of the contestant as of January 1. NOTE: Read this warning about 14 year old contestants. The following is a direct quote from the Wisconsin Interscholastic Athletic Association (W.I.A.A.) bulletin of January 23, 1987. "Boys and girls who aren't or won't be on a high school varsity team this season *are* not prohibited from participating in this activity during the school season. Keep in mind that if one student does participate and then later in the season has an opportunity to play varsity ball, **THAT CAN'T BE DONE**. A student forfeits the opportunity to be on the high school varsity that season by participating in our activity. So, if you have the knowledge of a particular boy or girl that has a chance to move up to varsity this year, don't let them take *part* in this activity .

ENTRIES:

In order to be eligible for competition, all entrants must register with a Knights of Columbus Council prior to beginning the competition. All applications must be made on the official entry form. Proof of age must accompany all applications.

PARTICIPATION:

All boys and girls in the 10 to 14 year old age groups who have completed an official entry form and supplied proof of age are eligible to participate. Each age group will compete only among themselves. There will be no competition among contestants outside their respective age groups. Entrants may compete in only one council competition.

CATEGORIES:

There will be five separate levels of competition. These are as follows: Council, District, Diocesan, State and International. It is the responsibility of the State Officials to inform every participating Council as to the dates, times, and locations of the Diocesan and State Competitions. State scores will be used to determine International winners. No International shoot-offs will be conducted.

PROGRESSION:

The winners at the Council level will progress to the District level. The winners there will go onto the Diocesan level and the Diocesan winners will proceed to the State Level. In the event that a winner at any level cannot participate, the second place winner should represent the area.

COUNCIL:

Council competition may be held on any local basketball court approved by and under the supervision of the Youth Committee of a participating Knights of Columbus Council. Participation certificates are provided by the Supreme Council for presentation to all entrants. The winners of this level of competition should also be awarded the certificates provided by the Supreme Council. Suitable awards should be supplied by the local Council.

DISTRICT:

District competition may be conducted on any local basketball court approved by and under the supervision of the District Deputy and a participating Knights of Columbus Council. Results must be forwarded by the District Deputy with all pertinent information to the Diocesan Coordinator. Awards for district competition are supplied to the District Deputy by the Supreme Council. Any additional awards may be supplied by the participating District Councils.

DIOCESAN:

The Diocesan Championships may be held on any local basketball court approved by and under the supervision of the Diocesan Coordinator. Results must be forwarded to the State Athletic Chairman with all pertinent information. Awards will be supplied by the State Council.

STATE:

State Championships competition may be held on any local basketball court approved by and under the supervision of the State Chairman and a participating Knights of Columbus Council. Results must be forwarded by the State Chairman to the Supreme Council Service Department on their forms. These reports will automatically constitute the entry of all Wisconsin State winners in the International competition. Awards will be supplied by the State.

INTERNATIONAL:

International winners are decided by the Supreme Council on the basis on scores achieved on the State Competition. Engraved awards will be supplied by the Supreme Council to the International winners.

SHOOTING PROCEDURE

Contestants should be permitted as many warm up throws as they deem necessary prior to the Competition. After competition begins and unless there is an unusual delay for any reason, (net or backboard problems, changing to another basket etc.) students are not permitted warm up throws. If any unusual circumstances not covered in the rules arise, an equitable decision must be reached by the director of that particular competition.

Council Level:

Each contestant will be allowed fifteen (15) free throws in five (5) throw increments from the foul line.

Note: standard free throws rules apply. Stepping over the line before the ball hits the rim or backboard is considered a miss. Winning contestants who are tied will progress to the second round, where they will shoot five (5) free throws. Successive rounds of five (5) free throws each will continue one contestant emerges as the winner.

District Level:

Each contestant will be allowed twenty five (25) free throws in five (5) throw increments from the foul line. The same five count progression method explained in the Council level will be used when breaking ties.

Diocesan Level:

Each contestant will be allowed twenty five (25) free throws in five (5) throw increments from the foul line. The same five count progression will be employed until a winner emerges.

State Level:

Each contestant will be allowed twenty five (25) free throws in five (5) throw increments from the foul line. The same five count progression will be employed until a winner emerges.

AWARDS

Council Level:

Each participating council should provide suitable awards to the winners. In addition, the Supreme Council furnishes, without cost, certificates for all participants in the competition as well as certificates for the Council Level winners.

District Level:

The Supreme Council will provide, without *cost*, medals for the ten winners in each district. However, if the medals are engraved, they must be done locally, and these costs must be assumed by the councils within the District or by the State Council.

Diocesan and State Levels:

The State Council will provide the First, Second and Third place winners with suitable awards. Cash prizes or bonds must not be awarded since this impairs the amateur status of the contestants.

JUDGES

Judges will be determined by the Grand Knight at the Council Level; the District Deputy at the District Level and by the State Deputy at the Diocesan and State Levels.

SPECIAL NOTE:

If the contestant is a winner in one or more of the Spelling, Math or Free-Throw contests, he or she will have to make a decision to compete in only one of the three at the Diocesan Level of competition. After the decision is made by the contestant, the second place winner in a non-selected contest will advance.

SAMPLE LETTER

Date

Dear (Principal or Coach):

(Name of Council and number) in conjunction with the "Wisconsin State Council, Knights of Columbus" invite all of your boys and girls 10, 11, 12, 13 and 14 to participate in our Free Throw Championships.

The contest will be held on (DATE) at (PLACE) at (TIME).

I have enclosed entry forms and rules which cover the contest. There are no fees for any child entering the contest and no equipment such as uniforms or balls are required. Our organization will provide all equipment needed.

All participants should take note of the deadline for mailing back the entry forms. They must be in my hands no later than (DATE). This is necessary to schedule entries and allow sufficient time to contact the contestants. It is important that a stamped, self-addressed envelope be sent to me with the entry forms so that time schedules can be mailed back.

Please feel free to call me if you have any questions that may not be covered in the enclosed information sheet.

Respectfully,

(NAME)
(ADDRESS)
(TELEPHONE)

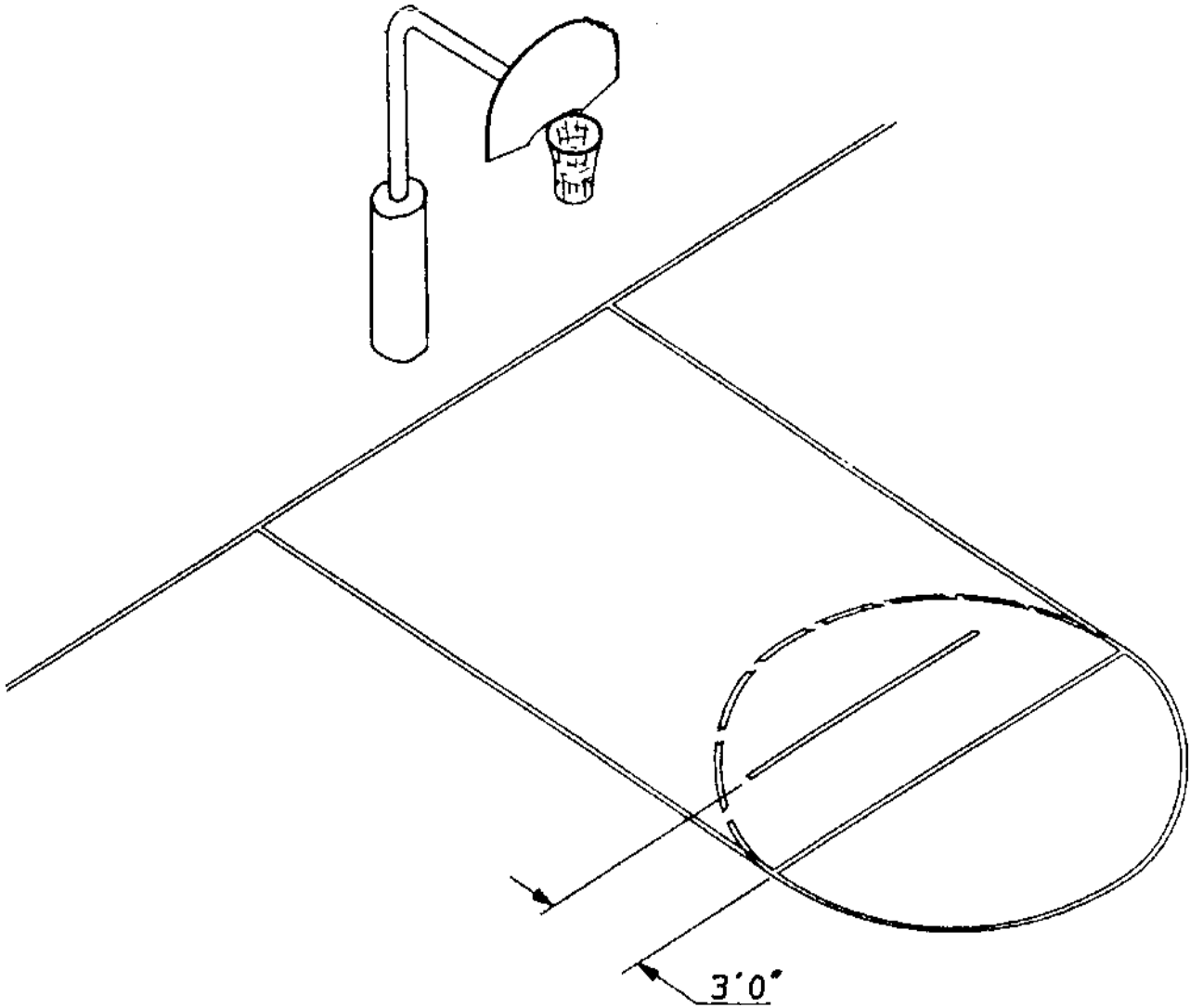

Please file this form listing the winners in each age group with Parent or Guardian release form. NOTE: File separate sheet for Boys and Girls

Grand Knights are to submit the Council winners on this form to your District Deputy.

District Deputies are to submit the District Winners on this form to your Diocesan Program Directors.

Diocesan Program Directors are to submit the Diocesan winners, FIRST and SECOND place in each age group to the State Director. (Separate sheets should be filed for first and second place winners.)

Signature: Grand Knight, District Deputy or Diocesan Coordinator

Wisconsin State Council Knights of Columbus



Free Throw Championship REPORT FORM

Boys _____ Girls _____

| | |
|--------------------|---------------------|
| COUNCIL NO. _____ | TOTAL ENTERED _____ |
| DISTRICT NO. _____ | TOTAL ENTERED _____ |
| DIOCESE _____ | TOTAL ENTERED _____ |

TOTAL ENTERED AGE 10 _____ 11 _____ 12 _____ 13 _____ 14 _____

10 Year Old Winner

| | | | |
|---------------|---------------------------|------------------|-----------------|
| Name _____ | Score _____ | District # _____ | Council # _____ |
| Address _____ | City _____ | Zip _____ | |
| Parents _____ | Telephone (_____) _____ | | |

11 Year Old Winner

| | | | |
|---------------|---------------------------|------------------|-----------------|
| Name _____ | Score _____ | District # _____ | Council # _____ |
| Address _____ | City _____ | Zip _____ | |
| Parents _____ | Telephone (_____) _____ | | |

12 Year Old Winner

| | | | |
|---------------|---------------------------|------------------|-----------------|
| Name _____ | Score _____ | District # _____ | Council # _____ |
| Address _____ | City _____ | Zip _____ | |
| Parents _____ | Telephone (_____) _____ | | |

13 Year Old Winner

| | | | |
|---------------|---------------------------|------------------|-----------------|
| Name _____ | Score _____ | District # _____ | Council # _____ |
| Address _____ | City _____ | Zip _____ | |
| Parents _____ | Telephone (_____) _____ | | |

14 Year Old Winner

| | | | |
|---------------|---------------------------|------------------|-----------------|
| Name _____ | Score _____ | District # _____ | Council # _____ |
| Address _____ | City _____ | Zip _____ | |
| Parents _____ | Telephone (_____) _____ | | |

Please file this form listing the winners in each age group with their Parent or Guardian release form.

NOTE: File separate sheet for Boys and Girls

Grand Knights are to submit their Council winners on this form to your District Deputy

District Deputies are to submit District Winners on this form and a copy of all-Council reports to your Diocesan Programs Coordinator.

Signature: _____

Grand Knight, Program Chairman, District Deputy